

APPLICATION NOTE

AN001_MPT1050xIQ and MPT1120xIQ Evaluation Board User Guide

The MPT1050xIQ or MPT1120xIQ are fully integrated step down DCDC converters with control/compensation, gate drive, MOSFET switches, and high performance magnetics. It comes in a 4mm x 6mm x 1.85mm low profile QFN package and requires only a small number of external components to make a complete converter solution.

This user guide should be used together with the latest eval board schematic revision.

The following are the features of this evaluation board.

- Populated with one MPT1050xIQ or MPT1120xIQ.
- Pads are available for a wide range of input and output capacitor configurations.
- Output voltage programming is accomplished via a simple resistor divider. Jumpers are provided for 5 pre-configured output settings. These settings are as follows:
0.6V, 1.2V, 1.8V, 3.3V, 5.0V
- Easy jumpers are provided for the following signals:
 1. Enable / Disable function
 2. Vout selection
- Numerous test points are provided as well as clip leads for input and output connections
- The board comes with input decoupling.

Figure 1 shows a photograph of the evaluation board. Please refer to this while configuring the board for evaluation.

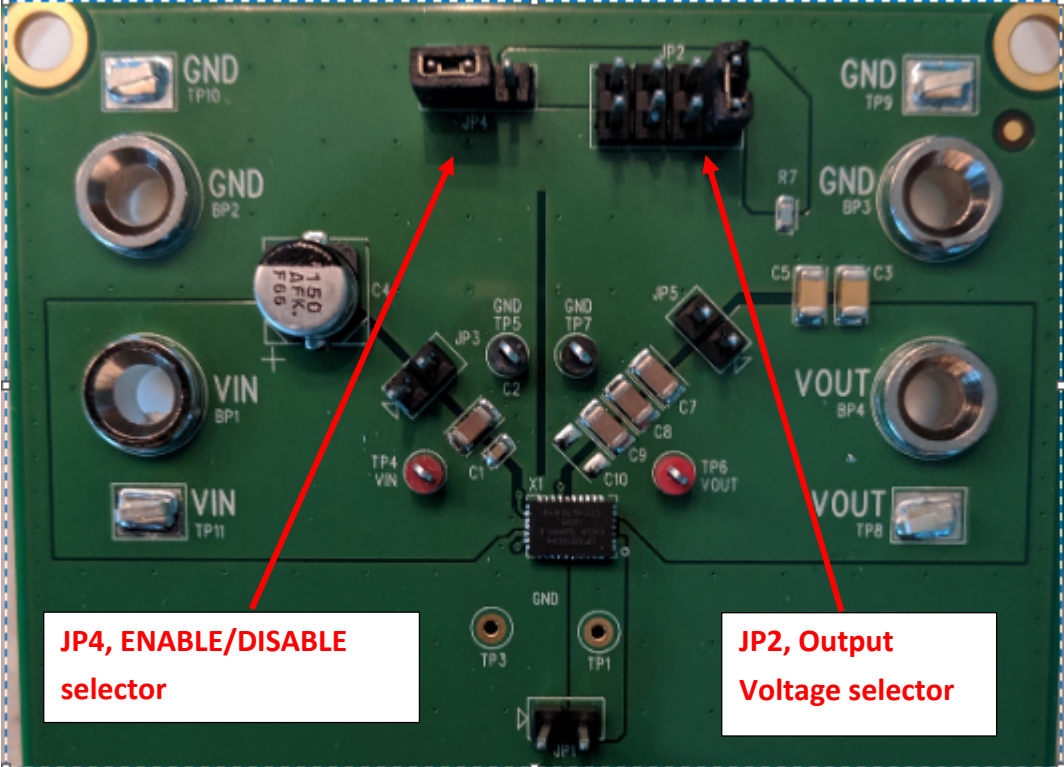

Figure 1: MPT1050xIQ and MPT1120xIQ Evaluation Board

Figure 2 is the evaluation board schematic. Please refer to this while configuring the board for evaluation.

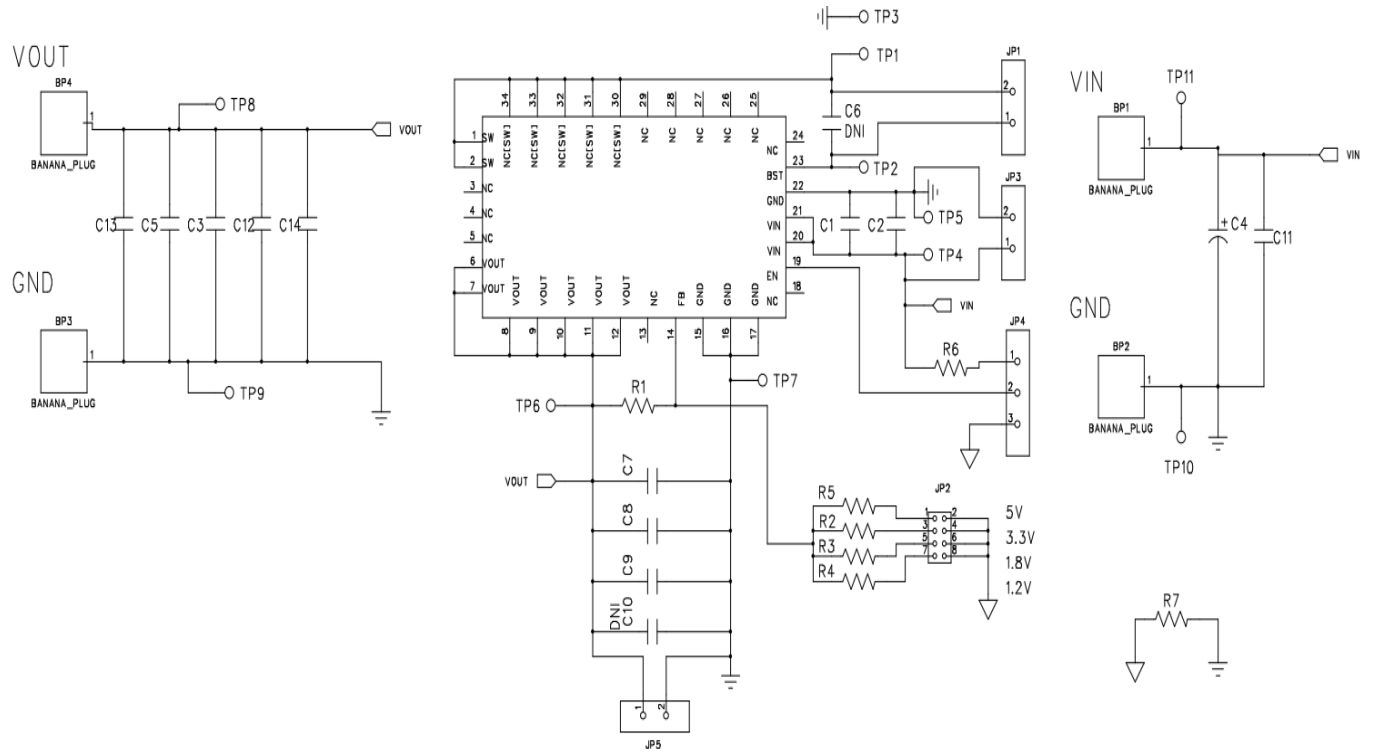

Figure 2: MPT1050xIQ and MPT1120xIQ Evaluation Board Schematic

BOARD POWER UP PROCEDURE

STEP 1: Set the “ENABLE” jumper to the Disable Position by placing jumper on pins 2 and 3 on JP4

STEP 2: Select the desired VOUT voltage setting by placing the jumper JP2 on the correct jumper pin.

Below shows the VOUT jumper options:

- VOUT = 5V, connect jumper to pins 1 and 2 on JP2
- VOUT = 3.3V, connect jumper to pins 3 and 4 on JP2
- VOUT = 1.8V, connect jumper to pins 5 and 6 on JP2
- VOUT = 1.2V, connect jumper to pins 7 and 8 on JP2
- VOUT = 0.605V, no jumper installed

CAUTION: the VOUT jumper settings can only be changed when the device is disabled. Failure to follow this guideline may result in damage to the part.

STEP 3: Connect the Power Supply to the input power connectors, VIN (+) and GND (-). **DO NOT** turn the power supply on yet.

CAUTION: be mindful of the polarity. Reversing polarity will result in damage to the part.

STEP 4: Connect an electronic load, or load board to the output connectors VOUT (+) and GND (-).

STEP 5: Power up the board and move the ENABLE jumper to the enabled position by placing jumper on pin 1 and 2 on JP4. (Pin 1 of JP4 is marked with an arrow on the board). The MPT1050xIQ or MPT1120xIQ is now powered up and should have a regulated output voltage.

CHOOSING OTHER VOUT OPTIONS

To choose output voltage settings other than those configured on this Evaluation Board, replace one or more of the resistors R5, R4, R3, or R2 per the formula below and set the jumper J2 accordingly.

$$R_x = \frac{R1 \times V_{ref}}{V_{out} - V_{ref}}$$

Since $R1 = 56k\Omega$ and $V_{REF} = 0.605V$, the equation becomes:

$$R_x = \frac{33.88}{V_{out} - 0.605} k\Omega$$

TEST MEASUREMENT RECOMMENDATIONS

To guarantee measurement accuracy, the following precautions should be observed:

- Make all input and output voltage measurements at the board using the test points provided. This will eliminate voltage drop across the line and load cables that can produce false readings.
- Measure input and output current with series ammeters or accurate shunt resistors. This is especially important when measuring efficiency.
- Use a balanced impedance probe tip across C_{OUT} to measure V_{OUT} Ripple to avoid noise coupling into the probe ground lead. The recommended probe configuration is shown in Figure 3.

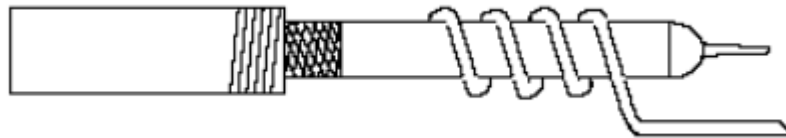

Figure 3. Recommended probe configuration.

Evaluation Board Ordering Information

Part Number	Evaluation Board (EVB)	Specifications
MPT10501IQ	MPT10501IQ-EVB	5V, 1A
MPT10502IQ	MPT10502IQ-EVB	5V, 2A
MPT10503IQ	MPT10503IQ-EVB	5V, 3A
MPT11201IQ	MPT11201IQ-EVB	12V, 1A
MPT11202IQ	MPT11202IQ-EVB	12V, 2A
MPT11203IQ	MPT11203IQ-EVB	12V, 3A